

(No Model.)

4 Sheets—Sheet 1.

J. B. SHERMAN & L. D. PHELPS.

Lathe for Turning Small Wooden Articles.

No. 242,993.

Patented June 14, 1881.

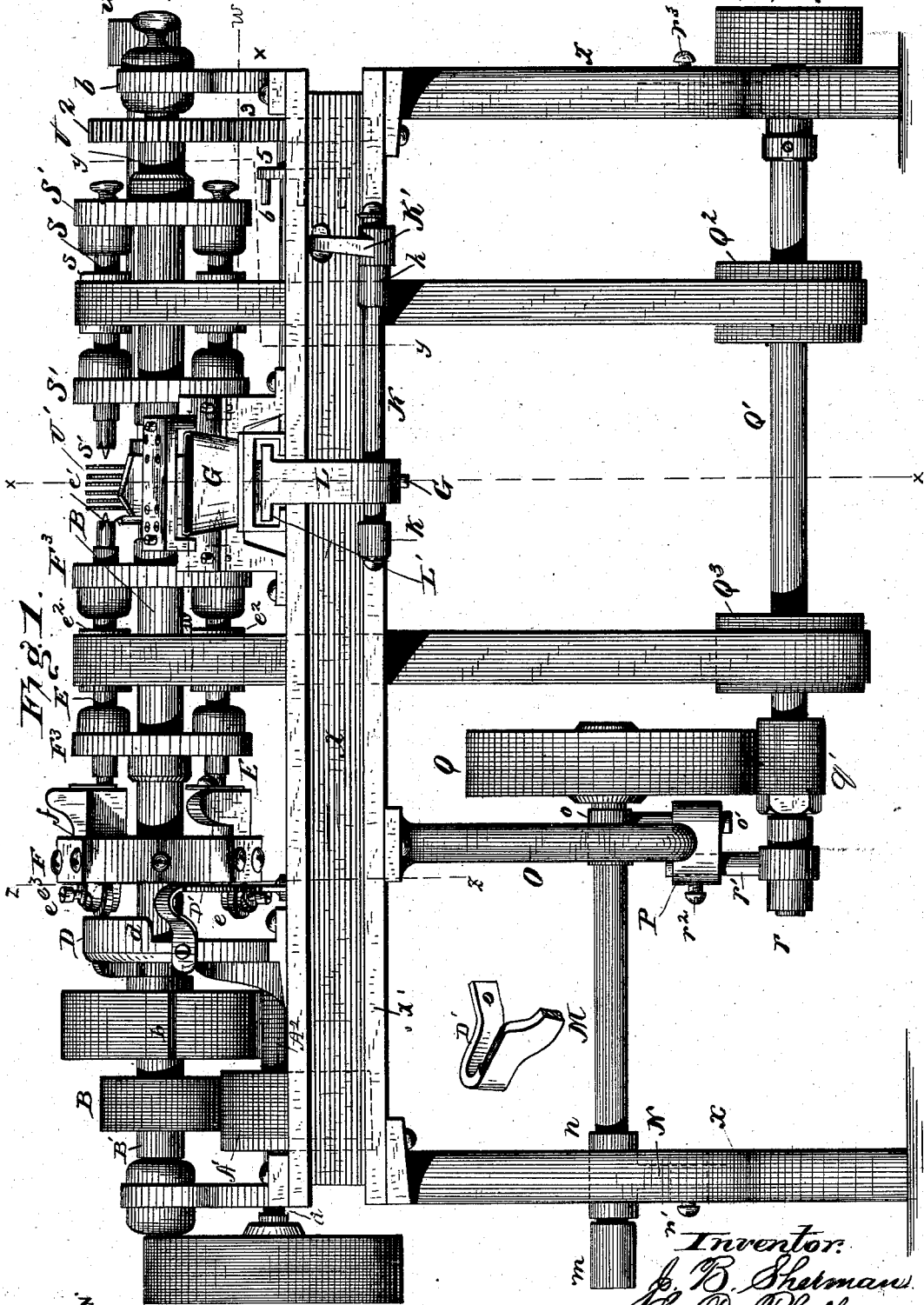

Witnesses.
 Frank L. Curand
 A. S. McCarthy

Inventor:
 J. B. Sherman
 L. D. Phelps.
 By Alexander D. Morrison
 Esq.

(No Model.)

4 Sheets—Sheet 2.

J. B. SHERMAN & L. D. PHELPS.

Lathe for Turning Small Wooden Articles.

No. 242,993.

Patented June 14, 1881.

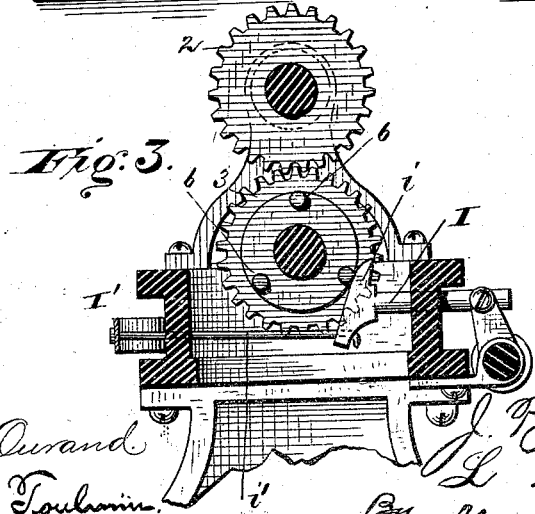
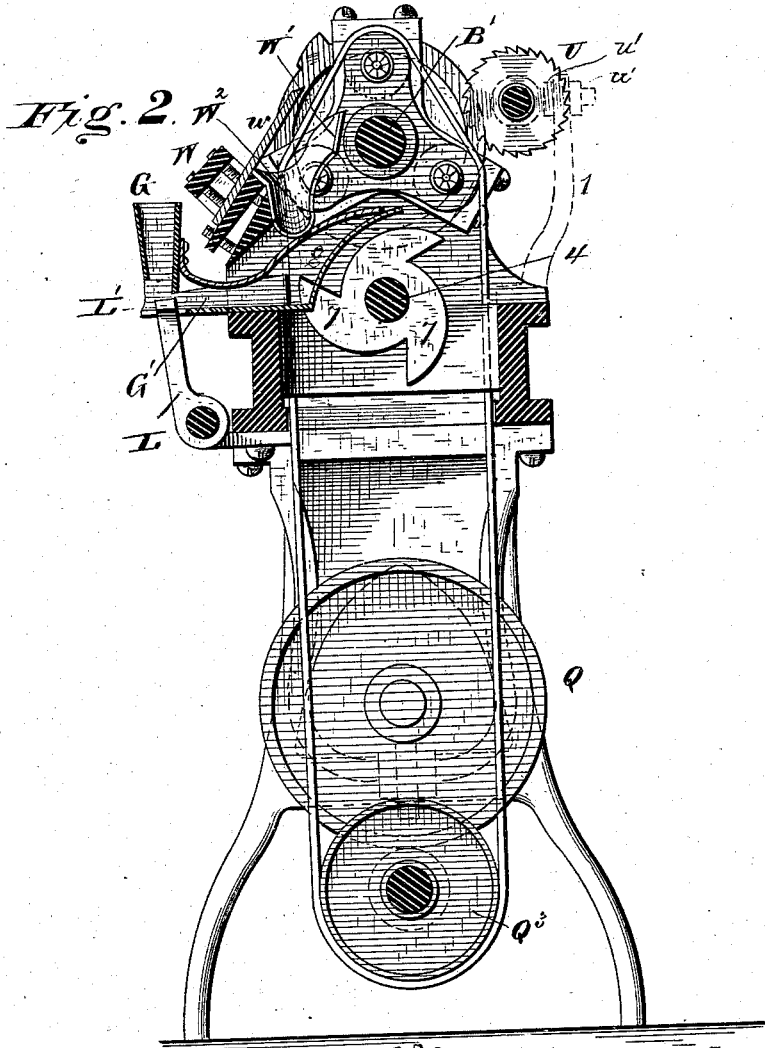

Witnesses:
 Frank L. Curand
 H. Aubrey Toubrin.

Inventor:
 J. B. Sherman and
 L. D. Phelps.
 By Alexander Mason
 atty

(No Model.)

4 Sheets—Sheet 3.

J. B. SHERMAN & L. D. PHELPS.

Lathe for Turning Small Wooden Articles.

No. 242,993.

Patented June 14, 1881.

Fig. 4.

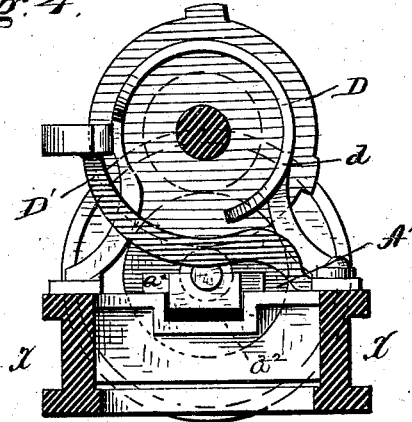

Fig. 5.

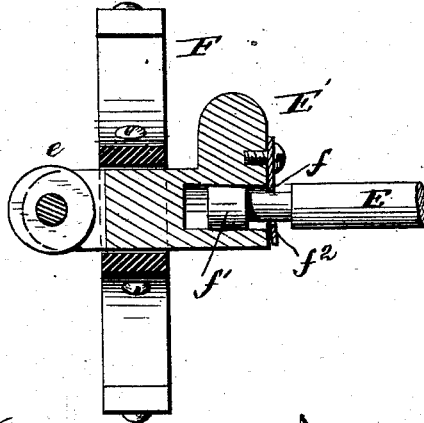
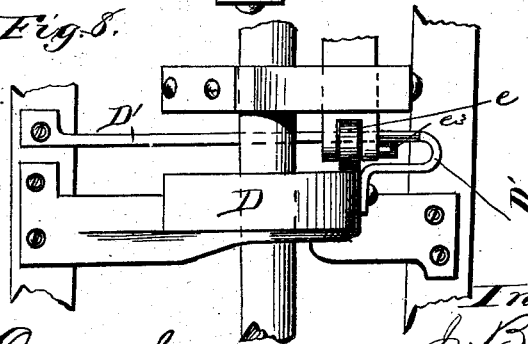

Fig. 6.



Witnesses,
 Frank L. Curand
 H. Aubrey Faulmer.

Inventor
 J. B. Sherman and
 L. D. Phelps.
 By Alexander Mason
 att.

(No Model.)

4 Sheets—Sheet 4.

J. B. SHERMAN & L. D. PHELPS.

Lathe for Turning Small Wooden Articles.

No. 242,993.

Patented June 14, 1881.

Fig. 6.

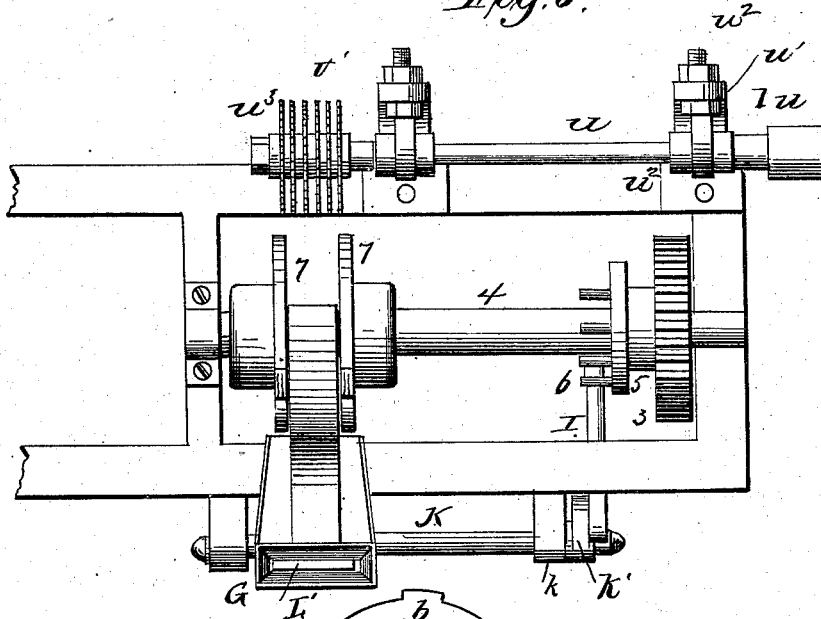
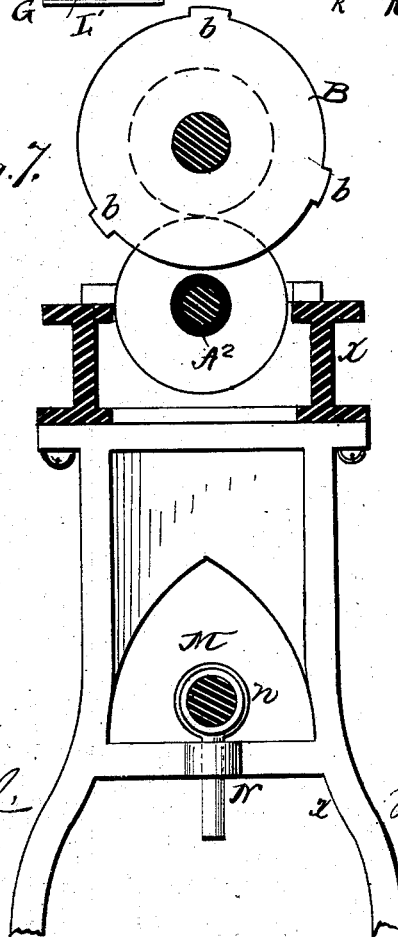

Fig. 7.



Witnesses.

F. L. Curran
J. J. McCarthy

Inventor
J. B. Sherman & L. D. Phelps
By Alexander T. Mason

UNITED STATES PATENT OFFICE.

JAMES B. SHERMAN, OF WATERLOO, AND LOREN D. PHELPS, OF BOLTON TOWNSHIP, COUNTY OF BROME, QUEBEC, CANADA; SAID SHERMAN ASSIGNOR TO CORTEZ C. ELDRIDGE, OF WATERLOO, QUEBEC, CANADA.

LATHE FOR TURNING SMALL WOODEN ARTICLES.

SPECIFICATION forming part of Letters Patent No. 242,993, dated June 14, 1881.

Application filed September 16, 1880. (No model.)

To all whom it may concern:

Be it known that we, JAMES B. SHERMAN, of the village of Waterloo, and LOREN D. PHELPS, of the township of Bolton, in the county of Brome, and in the Province of Quebec, Canada, have invented certain new and useful Improvements in Lathes for Turning Small Wooden Articles; and we do hereby declare that the following is a full, clear, and exact description thereof, reference being had to the accompanying drawings, and to the letters of reference marked thereon, making a part of this specification.

This invention relates to an improved compound lathe for turning clothes-pins, pail-handles, spools, bobbins, and other similar articles, wherein the blank is automatically fed to revolving spindles, then operated upon by cutting-tools, and discharged from the machine by the operation of suitable mechanical devices; and the improvement consists, primarily, in a revolving shaft supported in bearings upon the frame of the machine; and in securing to the said shaft a pair of frames provided with bearings in which three sets of spindles are supported and revolved, and also revolved with the said shaft and frames, each of the sets of spindles having an endwise motion to chuck and release the work at proper intervals; and in combining therewith a feeding device, a set of roughing saws and blades being arranged relatively to the spindles, so that each may operate upon different blanks at the same time.

The invention further consists in improved mechanism for feeding the blanks to the machine and delivering them at proper intervals to the spindles, the mechanism being arranged to register one with the other.

The invention finally consists in certain details of construction for supporting the spindles, adjusting the shafts, and operating the saw, as will be hereinafter more fully described and specifically pointed out.

In the drawings, Figure 1 represents a front elevation of the lathe; Fig. 2, a sectional view through the line xx of Fig. 1; Fig. 3, a sectional view through the line yy of Fig. 1; Fig. 4, a sectional view through the line zz of Fig.

1. Fig. 5 is a section showing the friction-roller, guide-block frame, and spindle of the revolving lathe-shaft; Fig. 6, a sectional elevation through the driving-pulleys in the line ww of Fig. 1; Fig. 7, a plan view, showing the saw and feed mechanism secured to the frame, with the other parts of the machine removed; and Fig. 8, a view in detail of the mechanism for moving the spindles longitudinally.

Referring to the drawings, the letter A indicates a power-pulley, mounted on a shaft, a , and having a rigid friction-wheel, A' , which operates in conjunction with a friction-wheel, B, mounted rigidly on a shaft, B' , which extends from one end of the frame x to the other.

The letter x' indicates the longitudinal plates of the frame, which frame has cross-bars, in which are hung the short shafts, as shown.

Upon the shaft B' are rigidly secured the double three-armed frames $F^3 F^3$ and $S' S'$, in which are freely journaled the ends of two sets of spindles, E and S, arranged in axial line with each other, each of which revolves with the shaft B' , and may be revolved in their bearings at a speed greater than that of the shaft B' , as will hereinafter appear. A third frame, F, is also secured to the shaft B' , and is provided with bearings for blocks E' , provided at one end with sockets, into which the ends of the spindles E are secured by means of plates f , that fit in circumferential grooves in said shafts, that serve to hold them in their sockets, but permit them to freely turn therein; and the other ends of said blocks are provided with friction-rollers e , that are held between the cam-surface d of standard D and a cam-plate, D' , arranged in proper relation to each other, and both secured to the frame, so that the friction-roller blocks and spindles will be moved longitudinally in their bearings, alternately in opposite directions, to gripe and release the work between the lathe-clutches or clutch-spindle points $e' s'$ on the ends of the spindles E S.

From the pulley A is belted a pulley, m , upon a shaft, M, adjustably secured within the frame x by being journaled within a socket, n , having a standard or arm, N, which is adjustably

held within a cross-bar of the frame x , and secured by means of a set-screw, n' , as shown. The shaft M is further journaled within a hanger, O, by means of a socket, o , and arm o' , said arm reaching down through a frame-piece, P. The shaft M carries upon its inner end, rigidly, a wheel or pulley, Q, which acts frictionally upon a pulley, q' , upon a shaft, Q'. This shaft Q' is adjustable at one end by means of a socket, r , having an arm, r' , which operates within the frame P, and is held at any point desired by means of a set-screw, r^2 , while at the other end it is hung within a socket having a similar arm, which is held adjustably in the frame x by means of the set-screw r^3 . By this means the shafts, with their pulleys and belts, may be adjusted in their frames and with each other to take up lost motion and have greater frictional contact with each other.

Upon the shaft Q' are hung two pulleys, the former, Q³, being belted to the pulleys e^2 upon the spindles E, and the latter, Q², being belted to similar pulleys, s , secured to the spindles S, and arranged between the three-armed frames S'.

Upon the outer end of the shaft Q' is secured a pulley, T, which is belted to a smaller pulley, u , hung upon standards 1, rigidly secured to the back plate of the frame x , and upon a shaft, U, carrying a gang-saw, U'.

Upon the shaft B' is rigidly secured a gear, 2, which meshes with a pinion, 3, upon a shaft, 4, journaled within the frame, and carrying a disk, 5, having pins 6, and also carrying a pair of three-armed plates, 7.

Passing transversely through the frame-plates x' is a bar, I, having a shoulder, i , against which the pins 6 operate, and to which is secured a rod, i' , which bears against the constant force of the spring I' upon the opposite side of the frame.

In journals k is loosely hung a rock-shaft, K, having a crank-lever, K', which is secured to the rod I, and rigid upon said rock-shaft K is a thrower, L, which operates within the chute L' beneath a hopper, G, and having a way, G', which leads to the arms of the plates 7 7 upon the shaft 4.

Adjustably secured within the frame W is a planing-knife, w , and between said knife and the shaft B' is an inclined chute, W², into which the work is deposited by the withdrawal of the spindles therefrom when the work has been finished.

The shaft a of the power-pulley transmits a rapid motion to the shaft B' by means of the pulleys A' and B, as above described, and an intermittent retarded motion by means of an elastic pulley, A², upon the shaft a and a pulley, B², of peculiar construction, upon the shaft B'. The pulley B² has formed upon its periphery three projecting ribs or enlargements, b b b , the faces of which are truly turned to be concentric with the shaft B'. The projections b are placed at equal distances apart around the pulley, and are arranged relatively to the arms of the plates F' F³ S' and to the knife

and saw blades, so that the said projections will come in contact with the driving-pulley A² to retard the speed of the shaft B' and the spindles E S when the said spindles are opposite the cutters and the work is being operated upon by them, the pulleys B and A' slipping upon each other, when the ridges b and pulley A² are in contact, by reason of the elastic seat a^2 giving to the bearing of the shaft of the pulley A². When the projections have lost contact with the pulley A² the shaft B' will be driven by the pulleys A' and B at an accelerated speed, and the spindles E S will be rapidly carried from the saws to the knife, or from one operative portion to another. The triangular arrangement of the spindles E S with the cutting-knives is such that when the work is being operated upon two of the spindles will be in a horizontal plane and the third will be immediately or centrally above them, and the belts that communicate motion to the pulleys will be stretched to their greatest tension while the work is being done and when the greatest power is required.

The blocks E' have rectangular sides and slide freely in their bearings in plate F, and their rollers e are held in place therein by screw-bolts e^3 , the heads of which project some distance from the blocks E', and are caught by the cam-blade D', that passes between them and the frame F and draws the rollers, with their blocks and shafts, in toward the plate D, so that they will be acted upon by the cam-face d , Fig. 4, thereof, to gripe and release the work.

The width of the hopper G and the movement of the lever L are such as to conform to the size of the blanks to be turned, so that when the lever is withdrawn from beneath the hopper a single block only will fall opposite the lateral opening to the guide-plates g g , and when the lever is pushed beneath the hopper the block will be forced up between the spring guide-plates a sufficient distance to be in position to be caught between the arms of the plates 7 7 and placed centrally in the line of rotation of the clutches of spindles E S, to be caught by them as they pass and be carried to the saws.

The saw-arbor U is supported upon arms 1 rigidly secured to the rear portion of the frame, and may be adjusted toward or from the shaft B' and its spindles E S, to suit the size of the work, by means of nuts w' w' upon the screw-threaded shanks of the bearing-blocks w^2 , the said nuts being arranged upon opposite sides of the arms 1. The saw-blades may be removed from the arbor by unscrewing the nut w^3 , and other intermediate washers of different sizes may be substituted therefor, in a well-known manner, to suit the outline of the work to be turned.

In the operation of this invention blocks of proper size are fed into the hopper G, and, reaching the chute L', they are automatically pushed or forced forward to the three-armed pick-up plates 7, and the action of the recip-

5 rotating spindles E, controlled by the rollers
 e and cam D, is such that the blank or block
 will be pinched by the holding ends of the
 lathe-spindles as soon as it leaves the chute
 L'. The block then receives from the pulleys
 10 Q² Q³, of equal size, upon the shaft Q' a rotat-
 ing motion, which carries it to the rotating
 gang-saws U', which, being operated by the
 multiplying-pulleys u T, acquire a sufficient
 15 force to give the block of unequal circumfer-
 ence an approximately true but rough exterior.
 It will be understood that the lathe-chucks or
 holding-points are revolving at a multiplied
 20 speed, and that the gang-saws operate and
 revolve in an opposite direction, which gives
 a proper speed to the saws upon the surface of
 the revolving blocks. From the saws the
 frames F³ S' and the revolving chucks or
 25 holders s' e carry the blocks thus rounded to
 the beveled plane W, which plane gives said
 blocks a smooth exterior, and thereafter, the
 blocks striking the chute W' W², they drop
 through the frame, and may be removed at
 will.
 30 It will thus be seen that the power derived
 from the pulley A by friction and otherwise op-
 erates not only the revolving gang-saw U', but
 that it drives, by the lever L, the blocks forward
 to the lathe-holding ends, and that the ends
 35 are engaged automatically to register perfectly
 by means of the cams D d, and that the pul-
 leys Q² Q³ and pulleys s e² upon the shafts E
 S serve to give the block or blank a multi-
 plied revolving motion, and that the same
 40 power not only receives the rough blank and
 feeds it to the chucks, but the mechanism is
 such that the chucks operate to grasp it, and,
 after being carried by the revolution of the
 shaft B', it is rounded by means of the gang-
 saws and carried to the plane W, where it is

smoothed and afterward discharged through
 the chute W' W².

Having described our invention, what we
 claim, and desire to secure by Letters Patent,
 is—

1. In a compound lathe for turning a num- 45
 ber of articles at the same time, the combina-
 tion of the shafts a B', pulleys A' B A², the
 pulleys A' and B being arranged to slip upon 50
 each other, and the pulley B² provided with
 projections b, a series of revolving spindles se-
 cured to shaft B', and cutters secured to a suit-
 able rest and arranged relatively to the pro-
 jections b, substantially as and for the pur-
 55 pose described.

2. In a lathe, the combination of the frame, 55
 the revolving shaft, a series of independently
 revolving and sliding spindles connected there-
 with, the vibrating feed-lever connected by in-
 60 termediate mechanism with the lathe-shaft,
 and the pick-up plates connected with said
 shaft and arranged to accurately register with
 the movements of the revolving spindles and
 feed-lever, substantially as and for the pur-
 65 poses specified.

3. In a lathe, the combination of the shaft 65
 B', with its revolving spindles, the shaft 4, the
 gear-wheels 2 3, the disk 5, with its projecting
 pins, the spring-bar I, rock-shaft K, feed-lever
 L, and feed-hopper, combined and arranged 70
 substantially as and for the purpose described.

In testimony that we claim the foregoing we
 have hereunto set our hands and seals this 31st
 day of August, 1880.

JAMES B. SHERMAN. [L. S.]
 LOREN D. PHELPS. [L. S.]

Witnesses:

CHARLES S. MARTIN,
 JOS. H. LEFEBRE.